

GESTRA Steam Systems

Product Range B

Control Unit NRS 1-40.1

NRS 1-40.1

System description

The equipment can be used as

- **Low level limiter** (min. water level alarm) or as low-level limiting system in conjunction with level electrode NRG 1x-40,
- **High level alarm** in conjunction with level electrode NRG 1x-41.1 and
- **Safety temperature controller/limiter** in conjunction with temperature transmitter type TRV 5-40.

A combination of these functions is possible.

The control unit NRS 1-40.1 has four limiting functions for monitoring the MIN/MAX water levels (low/high level alarms) and MAX temperature in steam and (pressurised) hot water plants in accordance with TRD and EN 12952 and EN 12953.

The CANopen protocol is used for the data transfer via CAN bus.

Only one limiting system with one control unit NRS 1-40.1 may be used per CAN bus network.

Function

At regular intervals the control unit NRS 1-40.1 evaluates the data telegram coming from the level electrodes NRG 1x-40, NRG 1x-41.1 and the temperature transmitter TRV 5-40. This data telegram contains:

- Alarm messages given by the level electrodes NRG 1x-41.1 NRG 1x-40, and the temperature transmitter TRV 5-40,
- The result of the self-checking routine (detection of measured value),
- The temperature in the electrode terminal box and the casing of the temperature transmitter.

When a level or temperature alarm is raised the safety circuit is interrupted after the de-energizing delay. The control unit does not lock automatically. This function must be implemented in the following circuit.

The self-testing routine checks the safety functions of the controller, the level electrodes and the temperature transmitter. This self-test is carried out every 3 seconds in the controller and every 10 seconds in all other pieces of equipment.

An additional self-testing routine checks every 6 hours the de-energizing of the output relays in the controller.

Malfunction messages are updated during each self-checking routine. If there is no malfunction the messages will be deleted automatically and the safety circuit is closed again. However, if the malfunction still persists, the malfunction message will remain.

Alarm and malfunction messages are indicated by LEDs, and the signal output is instantaneously energized.

Design

NRS 1-40.1

Insulated casing with box terminals for installation in control cabinets. The terminals are externally accessible. The unit can be snapped onto a standardized 35 mm supporting rail type TH 35, EN 60715.

External dimensions: 100x73x118

CAN-Bus

All controllers and associated equipment (for level and conductivity monitoring) are interconnected by means of a CAN bus using the CANopen protocol to BS ISO 11898. Every item of equipment features an electronic address (node ID). The four-core bus cable serves as power supply and data highway for high-speed data exchange. NRS 1-40.1 is pre-configured at our works and ready for operation with other GESTRA devices. NRS 1-40.1 can be used immediately without having to change the node ID.

Technical Data

Type approval no.

TÜV. SWB / SHWS. 03 – 413

EG BAF-MUC 03 07 103881 004

Input/output

Interface for CAN bus to ISO 11898 CANopen

Output voltage supply for sensors

18 – 36 V DC, short-circuit protected

Output safety circuit

2 volt-free relay contacts, locally connected in series. Contact material AgNi 0.15.

Max. contact rating with a switching voltage of 24 V AC/DC, 115 V AC and 230 V AC: resistive / inductive 4 A.

Provide contactors with RC combinations according to manufacturer's specification to ensure interference suppression

Signal output

1 Photo MOS output for external signalling, alarm signal instantaneous, malfunction signal timed.

24-230 V AC / DC, max. current rating 100 mA, NO contact.

Factory setting of de-energizing delay of output relay

3 seconds,
other time delays (15, 25, etc.) on request

Indicators and adjusters

4 Pushbuttons for operation / "TEST",

4 LEDs for alarm and malfunctions messages,

1 LED "Power",

1 LED bus status, controller malfunction message

1 Ten-pole code switch for setting node ID and baud rate.

1 Six-pole code switch for system configuration

Internal self-checking routine

Every 3 seconds

Periodic testing of output relay contacts

Every 6 hours

Mains supply

230 V + 10 / - 15 %, 50 - 60 Hz or

115 V + 10 / - 15 %, 50 - 60 Hz

Power consumption

10 VA,

Protection

Casing: IP 40 to EN 60529

Terminal strip: IP 20 to EN 60529

Sensitivity of response

From 0,5 µS/cm at 25°C

Admissible ambient temperature

0 - 55°C

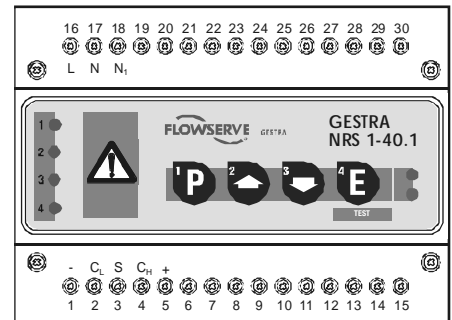

Control Unit NRS 1-40.1

Technical Data - continued-

Casing

Casing material: Base: black polycarbonate;
Front panel: grey polycarbonate,
Cross section of connector: 1 x 4.0 mm² solid or
1 x 2.5 mm² stranded wire with sleeve to DIN 46228 or
2 x 1.4 mm² stranded wire with sleeve to DIN 46228
Terminal strips separately detachable
Fixing of casing: Mounting clip on supporting rail TH 35,
EN 60715.

Weight

Approx. 0,8 kg

Important Note

Note that screened multi-core twisted-pair control cable is required, e. g. UNITRONIC® BUS CAN 2 x 2 x...mm² or RE-2YCYV-fl 2 x 2 x...mm². Max. cable length: 125 m for 250 kBit/s. The bus **must** be wired in series. Star-type wiring is **not** permitted!

Approximate values of cable lengths between two bus devices (length of segment) and of conductor sizes (following the specifications of ISO 11898):

Length of segment [m]	Number of pairs and conductor size [mm ²]
up to 250	2x2x0.34
250 up to 335	2x2x0.5
335 up to 1000	2x2x0.75

To protect the switching contacts fuse circuit with 2.5 A (anti-surge fuse) or according to TRD regulations (1.0 A for 72 hrs operation).

When using the control unit NRS 1-40.1 for more than two limiting functions the CAN bus must be supplied with 24V DC by a safety power supply unit (e. g. Siemens SITOP Power 05).

The power supply unit must be in accordance with DIN VDE 0106 (safety separation) and fused with an over-current protective device to EN 61010-1 / VDE 0411.

The CAN bus supply must not be connected to terminals 1 and 5.

Order & Enquiry Specification

GESTRA Control unit NRS 1-40.1 CANopen

Mains voltageV

Ancillary Units

- Level electrodes NRG 1x-40
- Level electrodes NRG 1x-41.1
- Temperature transmitter TRV 5-40
- Safety powersupply unit (e.g. Siemens SITOP Power 05)

Supply in accordance with our general terms of business.

Dimensions

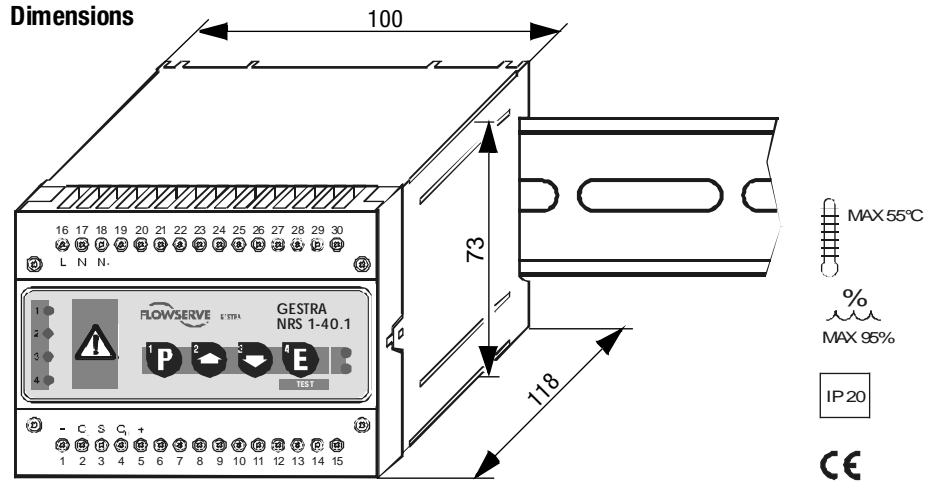

Wiring diagram

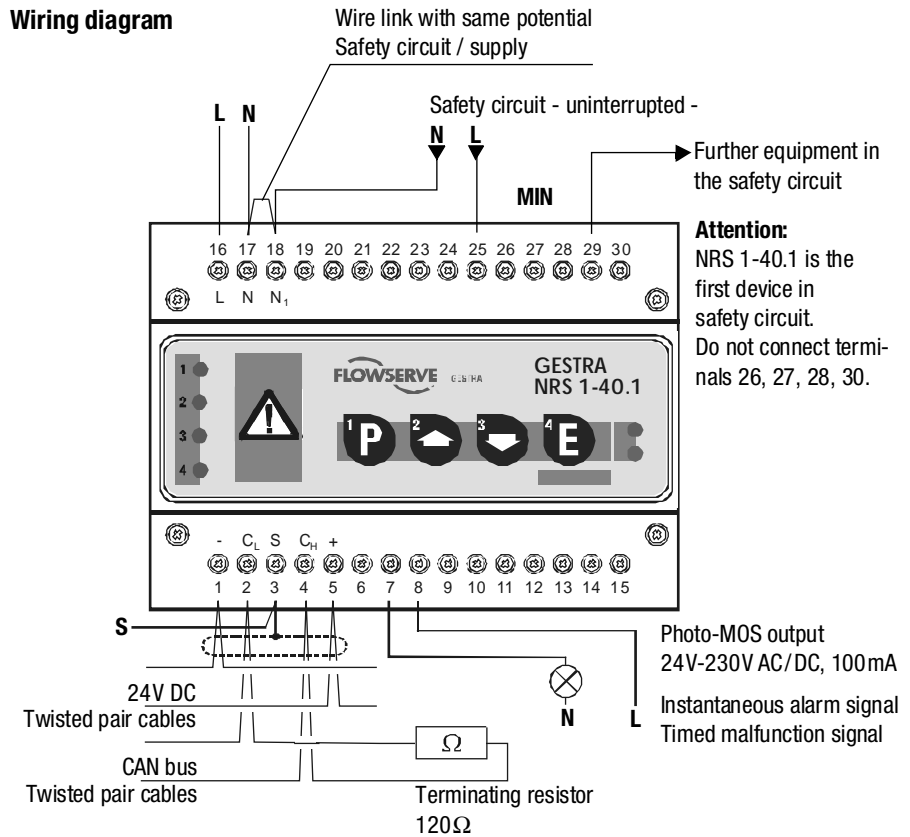

GESTRA AG

Münchener Straße 77, 28215 Bremen, Germany
Telefon +49 421 3503-0, Telefax +49 421 3503-393
E-mail info@de.gestra.com, Web www.gestra.de

